

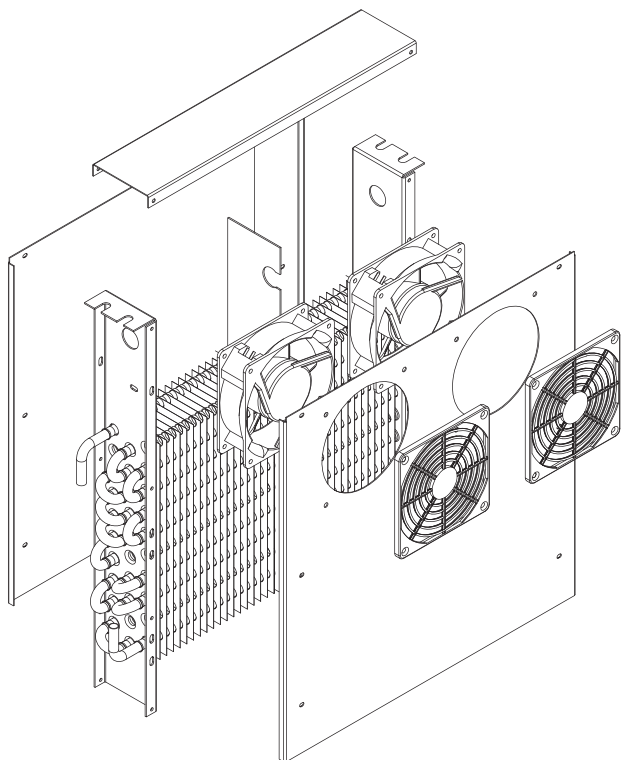

**AEROEVAPORATORI COMPATTI
PER MOBILI REFRIGERATI**
COMPACT UNIT COOLERS
FOR REFRIGERATED CABINETS

RIVACOLD
MASTERING COLD

RM70



CARATTERISTICHE GENERALI

Batteria

- Alette in alluminio
- Tubo in rame 3/8"
- Verniciata a polvere epossidica RAL7035.

Motoventilatore

- Ventilatore assiale compatto con motore monofase 220-240V/50-60Hz, supporto a cuscinetto, cablati con cavo di alimentazione.

Carenatura

- Realizzata in alluminio, adotta soluzioni costruttive che conferiscono robustezza e garantiscono l'assenza di vibrazioni durante il funzionamento. Viti, rondelle e dadi sono di acciaio inossidabile.

Bacinella (optional)

- Smontabile, per rendere reversibile la posizione del tubo di scarico.

Collaudo

- La batteria viene collaudata ad una pressione di 25 bar.

GENERAL FEATURES

Coil

- Aluminium fins
- 3/8" copper tube
- Epoxy powder varnished RAL7035.

Fan motor

- Compact axial fan motor, with bearing support. Voltage: one phase fan motor 220-240V/50-60Hz. Wired up with power supply cable.

Housing

- The housing is made of aluminium. The manufacturing solutions in use give the housing a specific strenght avoiding vibrations while operating. Screws, washers and nuts are made of stainless steel.

Tray (optional)

- The tray is removable in order to make the discharge pipe position reversible.

Test

The coil is tested at a pressure of 25 bar.





**AEROEVAPORATORI COMPATTI
PER MOBILI REFRIGERATI**
COMPACT UNIT COOLERS
FOR REFRIGERATED CABINETS

RM70

4,5mm Passo alette / Fin spacing

Modello Model		RM70/347 RM70/347 C	RM70/348 RM70/348 C	RM70/349 RM70/349 C	RM70/350 RM70/350 C	RM70/420 RM70/420 C
Capacità ΔT 10 T.cella 2°C UR 76% Capacity ΔT 10 Room T. 2°C RH 76%	W	433	496	589	658	746
Portata d'aria Air flow	m ³ /h	145,7	138,1	122,8	117,5	106,8
Freccia d'aria Air throw	m	1,78	1,67	1,50	1,39	1,23
Ventilatori Fan motors	n°	2	2	2	2	2
Assorbimento motori Fan motor power consumption	1~230V 50Hz	W	2 x 23	2 x 23	2 x 23	2 x 23
		A	2 x 0,15	2 x 0,15	2 x 0,15	2 x 0,15
Dimensioni Dimensions	A	mm	390	390	390	440
	B	mm	330	355	405	455
	C	mm	368	368	368	418
	D	mm	420	420	420	456
Attacchi Connections	entrata / inlet	Ø mm	9,52	9,52	9,52	9,52
	uscita / outlet	Ø mm	9,52	9,52	9,52	9,52
Volume circuito Circuit volume	dm ³	0,38	0,45	0,61	0,76	1,03
Superficie totale Total surface	m ²	1,16	1,40	1,86	2,33	3,21
Peso Weight	kg	3,0	3,3	3,9	4,2	5,1
Bacinella (optional) Drip tray (optional)		V004610	V004610	V004610	V004610	V004609

RM70/...

RM70/...C

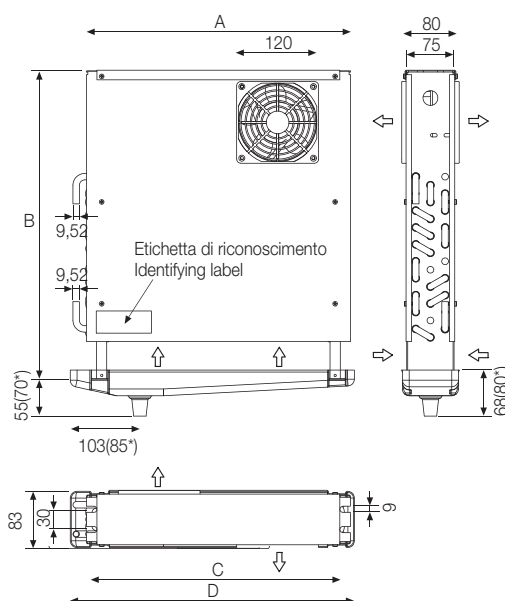
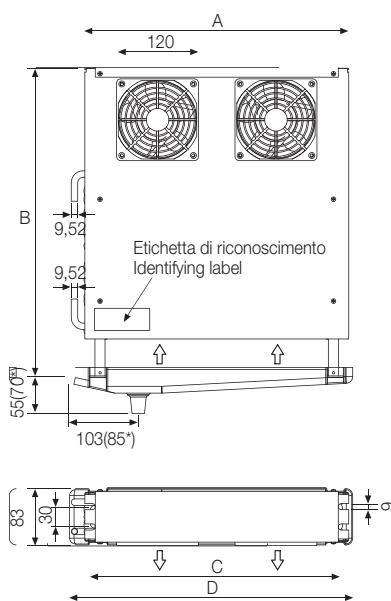

* Valori riferiti al gocciolatoio V004609 su RM70/420 e RM70/420...C
Per ulteriori informazioni, contattare il nostro ufficio tecnico

Descrizione, dati tecnici e illustrazioni sono indicativi e non vincolanti. La Rivacold si riserva il diritto di modificare per intero o in parte le specifiche descritte nella presente documentazione senza preavviso e a beneficio della continuità produttiva, di utilizzare produttori alternativi di componenti previsti nel progetto.

* Values refer to the drain pans V004609 on RM70/420 et RM70/420...C
For further information, please contact our technical department.

Descriptions, technical data and pictures are to be considered as a guide and not binding. Rivacold reserves the right to change in whole or part, the specification detailed in this documentation without prior notice and, when necessary to achieve continuous productions, to use alternative manufactures of components for design accomplishment.